



# OPTIMA EST Series **USER'S MANUAL**

Operating & Maintenance Instructions



Manufactured by  
**SJE Corporation, Ltd.**



# **User's Manual**

Operating and Maintenance Instructions

Model: OPTIMA EST Series

<For EST(05K, 12K, 18K, 27K), EST(S-05K, S-12K, S-18K, S-27K)>

Ver. 3.0

Distributor's Contact Information:

*Published by* **SJE Corporation, Ltd.**  
Copyright © 2013 by SJE Corporation, Ltd.

78-21, Sandan 7-Ro, Jeonggwan-Myeon, Gijang-gun  
Busan, Republic of Korea  
**Tel:** +82 51-521-3200  
**Fax:** +82 51-521-3305  
**Website:** <http://www.sjecorp.com>  
**E-mail:** [info@sjecorp.com](mailto:info@sjecorp.com)

*All rights reserved. No part of this publication may be reproduced, stored in a retrieval system, or transmitted, in any form or by any means, electronic, mechanical, photocopying, recording, or otherwise, without the prior permission of SJE Corporation, Ltd.*

Printed in Republic of Korea  
SJE20130930

# ***Table of Contents***

---

Introduction-----	1
Intended Applications-----	1
Safety Precautions ---	1
Symbols Key-----	3
Product Specifications-----	4
Exterior Dscriptions-----	5
Pre-start Procedures-----	7
Initial Operation -----	9
Standard Operating Procedures -----	10
Moisture Control -----	11
Pause Operations -----	12
Shutdown Procedures-----	12
Freeze Prevention-----	13
Maintenace-----	15
Safety Features -----	오류! 책갈피가 정의되어 있지 않습니다.
Troubleshooting Guidance -----	221

# ***Introduction***

---

The Optima Steamer represents the future of environmentally friendly and effective cleaning. Safe, durable and easy to use, the Optima will support your cleaning operations for many years to come.

# ***Intended Applications***

---

The Optima Steamer is designed for cleaning surfaces capable of handling steam jet pressure of up to 8 bar (116psi) and maximum temperatures reaching at 135°C (275°F).

The Optima Steamer is capable of cleaning various surfaces including, but not limited to machinery/parts, vehicle exteriors and interiors, engine compartment, glass, metal surfaces, windows, wheel wells, vents, kitchenware, remove weeds and much more while simultaneously sanitizing and deodorizing with very little water consumption.

# ***Safety Precautions***

---



Before operating the Optima for the first time, read the manual completely.

The manufacturer and distributors are not liable for the mechanical troubles, property damage, or personal injury caused by the operator(s) unfamiliarity with the manual's instructions.

- With regards to the steam vessel, use only water and the manufacturer's recommended steam vessel cleansing solution. Do not put any other chemicals or detergents into the water tank or steam vessel.
- Do not use distilled water or filtered water under 2ppm.
- "Soft" water is recommended. Otherwise, use only clean tap water with anti-scaling solution.
- The electric supply connection should be done by a qualified electrician and complied with IEC 60364-1.
- Make sure that all the switches on the machine are off before plugging the machine into an electrical outlet.
- If an extension cord is used, insure that it is constructed waterproof and of proper diameter based on the cord length and required the electrical specifications.
  
- Turn off and unplug the machine from its power source and allow the Optima Steamer to cool down before carrying out any maintenance.
- Use only hoses, steam-guns and all other accessories recommended by the manufacturer. Use manufacturer approved parts only.
- Use and store the Optima on a leveled up surface only.
- Do not use the machine in rain or snow outdoors. The Optima Steamer is not weather-proof or water-proof.
- Never leave the machine unattended while in use.
- Never store the machine below 32°F (0°C) or extremely cold weather condition.
- In cold climates, do not allow water to sit when the Optima is not in use. Do not operate the machine if any parts are frozen or suspected of being frozen. (See page13)

- Do not use the Optima if any part, power cord, safety device, hose or spray gun is visually damaged or suspected of being damaged.
- Use proper ear, eye and hand protection when operating the Optima. Noise can be generated from steam pressure and it can be reach 95 decibels (dB).
- Do not use the machine within the reach of people who are not wearing any protective gears.
- Do not direct the steam jet spray, aim or discharge at itself, live electricity, people or animals.
- The machine is not to be used by children or persons with reduced physical, sensory or mental capabilities, or lack of experience and knowledge, unless they have been given supervision or instruction.
- Keep the Optima away from children and animals at all times.
- Children should be supervised to ensure that they do not play with the machine.
- Never disable a sensor in order to bypass an alarm.
- To provide continual protection against risk of the electric shock, connect properly to grounded outlets only.

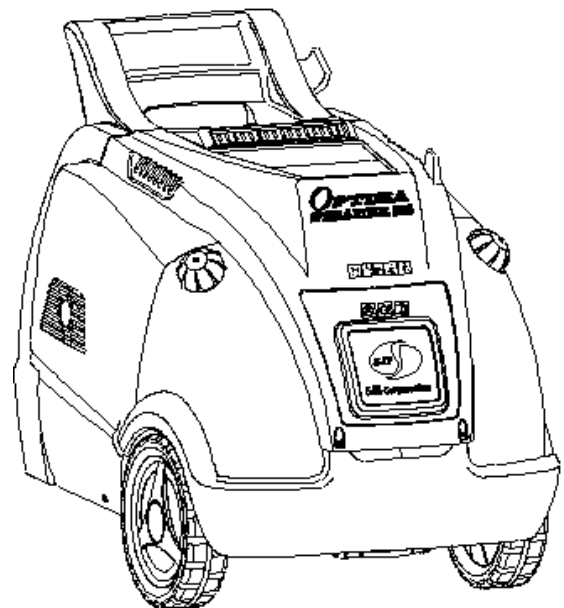
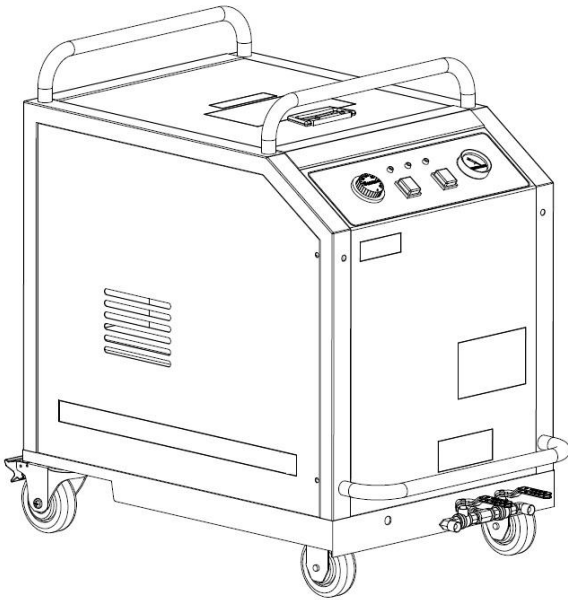

# Symbols Key

---



Do not direct the steam jet at people, live electricity, animals, etc.



Read the manual.



Warning: risk of burns.



Water pump



Feed-Water



Warning: risk of electric shock.



Water supply connection.



Caution.



Pressure gauge



Ground



Thermostat



Main power



Electric Heater



Steam jet

## LED Light and Alarm Indication



Main POWER on.



Water pump run on.



Water pump over-run flashing.



Low water level detection error on.



Water tank level low flashing.



Alarm beeps once.



Alarm beeps continuously.

# ***Product Specifications***

Model Name	Optima EST(05K,12K,18K,27K )				Optima EST(S-05K,S-12K,S-18K,S-27K )			
Capacity Display	05K	12K	18K	27K	05K	12K	18K	27K
Working Pressure	8 kg/cm <sup>2</sup> (bar) / 116 psi (Max. 10 kg/cm <sup>2</sup> / 145 psi)							
Working Temperature	< 135°C / 275°F							
Boiler/Steam Temperature	174°C / 346°F (Max. 180°C / 356°F)							
Preheating Time (in minutes)	21	9	7	6	21	9	7	6
Rated Electric Power (KW)	5.2	12.2	18.2	27.2	5.2	12.2	18.2	27.2
Voltage / Hertz (Customization available in the specified range)	200 ~ 240V, 50/60 Hz	200 ~ 480V, 3Ph, 50/60 Hz			200 ~ 240V, 50/60 Hz	200 ~ 480V, 3Ph, 50/60 Hz		
Water Tank Capacity	40 ℓ / 10.6 gals				4 ℓ / 1.06 gals			
Water Consumption Rate (Max)	300 cc/min	600 cc/min	600 cc/min (0.165 gpm) x 2 hoses		300 cc/min	600 cc/min	600 cc/min (0.165 gpm) x 2 hoses	
Net Weight (kg/lbs)	74 kg / 163 lbs			83 kg / 183 lbs	72 kg / 158 lbs			81 kg / 178 lbs
Net Dimensions	109 x 70 x H90 cm (43" x 28.3" x H35.4")				78 x 50 x H76 cm (43" x 28.3" x H35.4")			

**Note!**

\* To ensure safety and machine effectiveness, do not modify factory settings for steam pressure and temperature.

\* Water consumption rate may vary based on the use of the moisture valve. (See page 11)



# **Exterior Descriptions**

**Model Name: EST (05K,12K,18K,27K)**

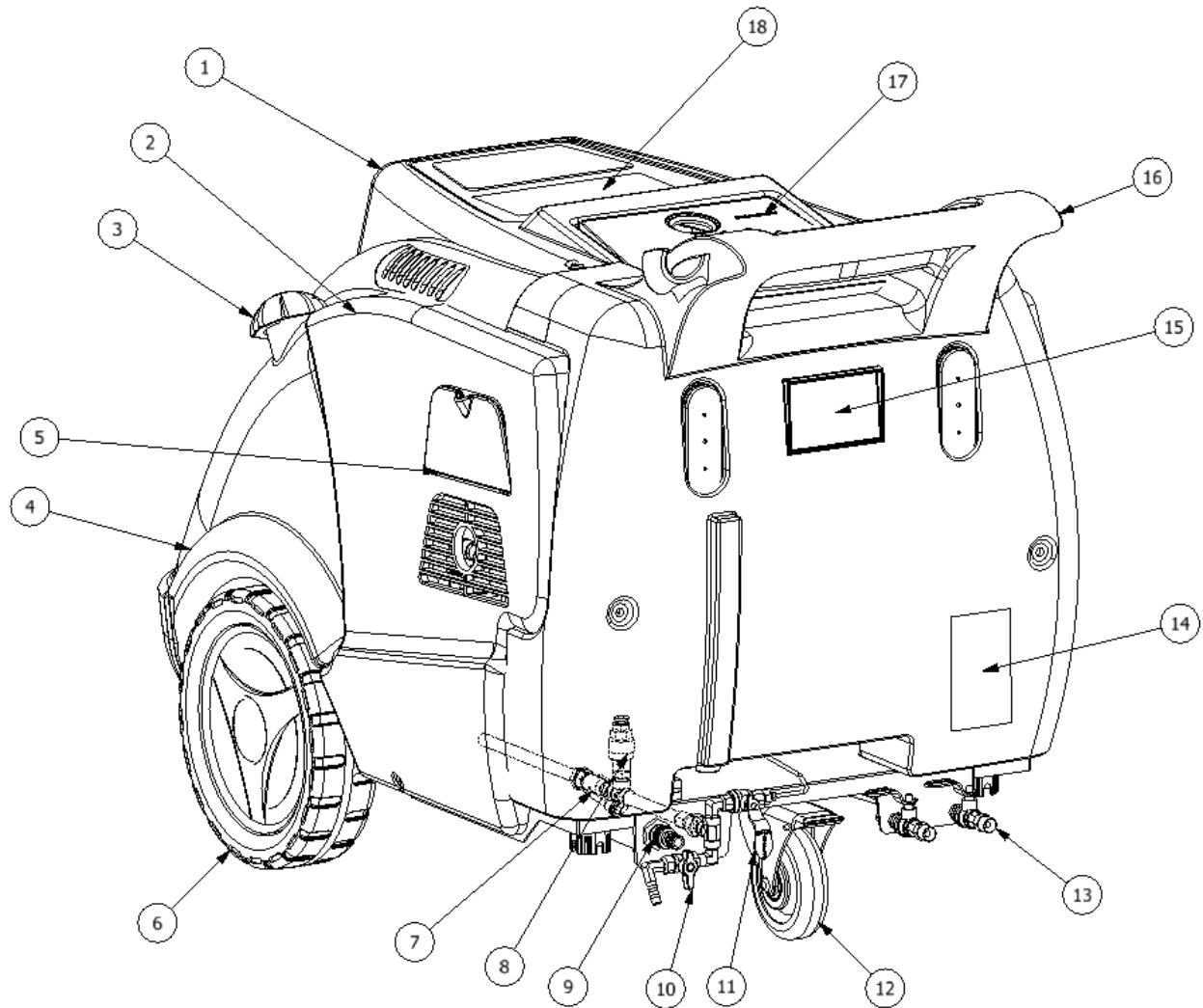

- |                              |                                   |
|------------------------------|-----------------------------------|
| 1. Top Cover                 | 10. Drain valve                   |
| 2. Lateral/Side panel        | 11. Moisture control valve        |
| 3. Tank cap                  | 12. Turning wheel with brake      |
| 4. Water tank                | 13. Steam outlet                  |
| 5. Throttle door             | 14. Warning sticker               |
| 6. Front wheel               | 15. Specification sticker         |
| 7. Y-strainer                | 16. Handle                        |
| 8. Non-return valve          | 17. Control box                   |
| 9. Quick Plug for feed-water | 18. Operating instruction sticker |

# **Exterior Descriptions**

**Model name: EST(S-05K,12K,18K,27K)**

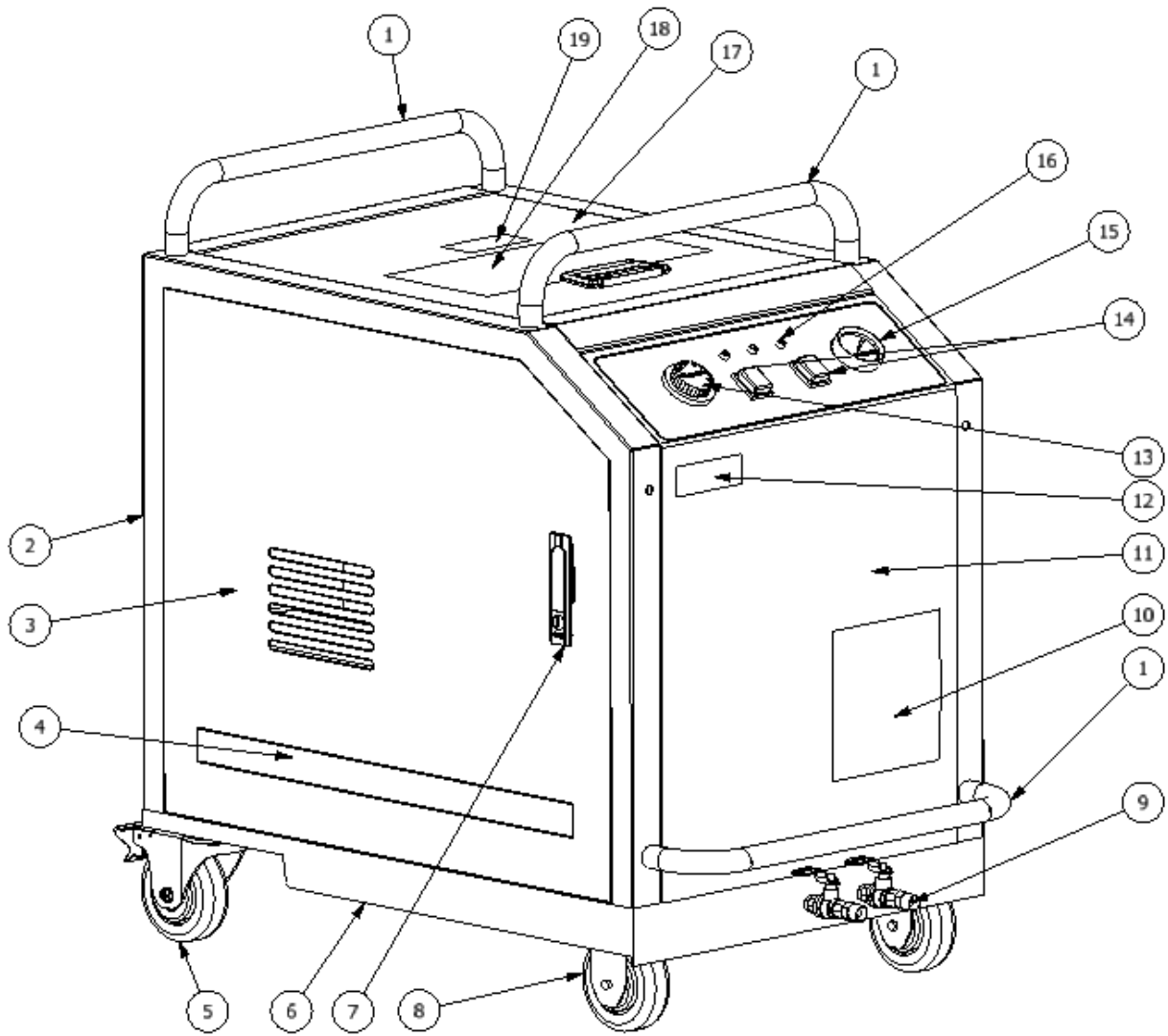

1. Handle	11. Front cover
2. Frame	12. sticker of Certification
3. Lateral/side panel door	13. Thermostat
4. Label sticker (Brand name)	14. Operating switches
5. Turning wheel with brake	15. Pressure gauge
6. Chassis	16. LED signal lights
7. Door lock/knob	17. Top cover
8. Stationary wheel	18. Operating instruction sticker
9. Steam outlet	19. Attention sticker
10. Warning sticker	

# Pre-start Procedures

## Steps:

1. Connect the steam hose and gun to the steam outlet valve. Ensure a tight connection (use tools).

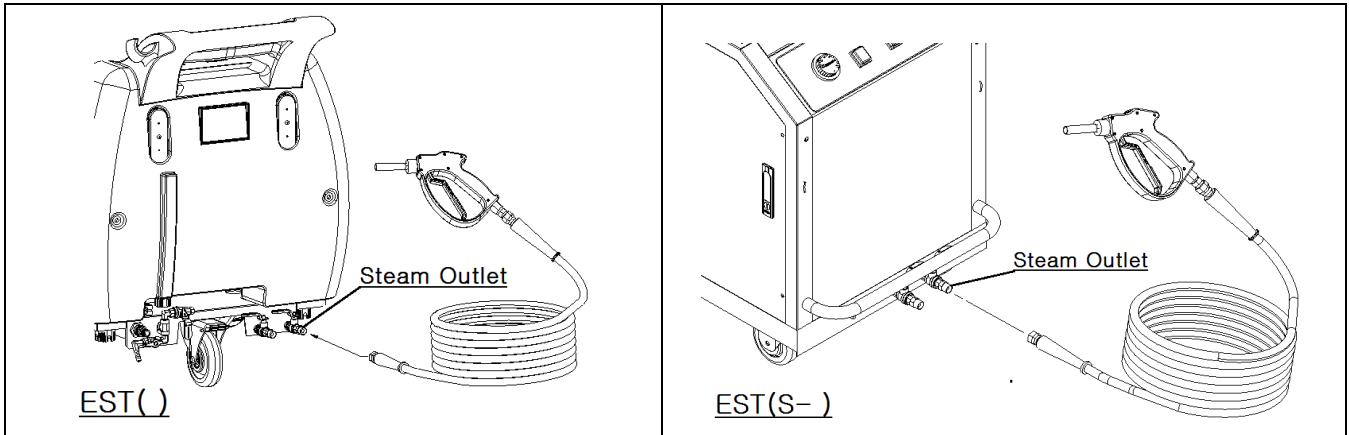

2. Fill the water tank with soft water. When tap water is used, add water treatment to the water tank as instructed by the supplier. Do not use distilled water.

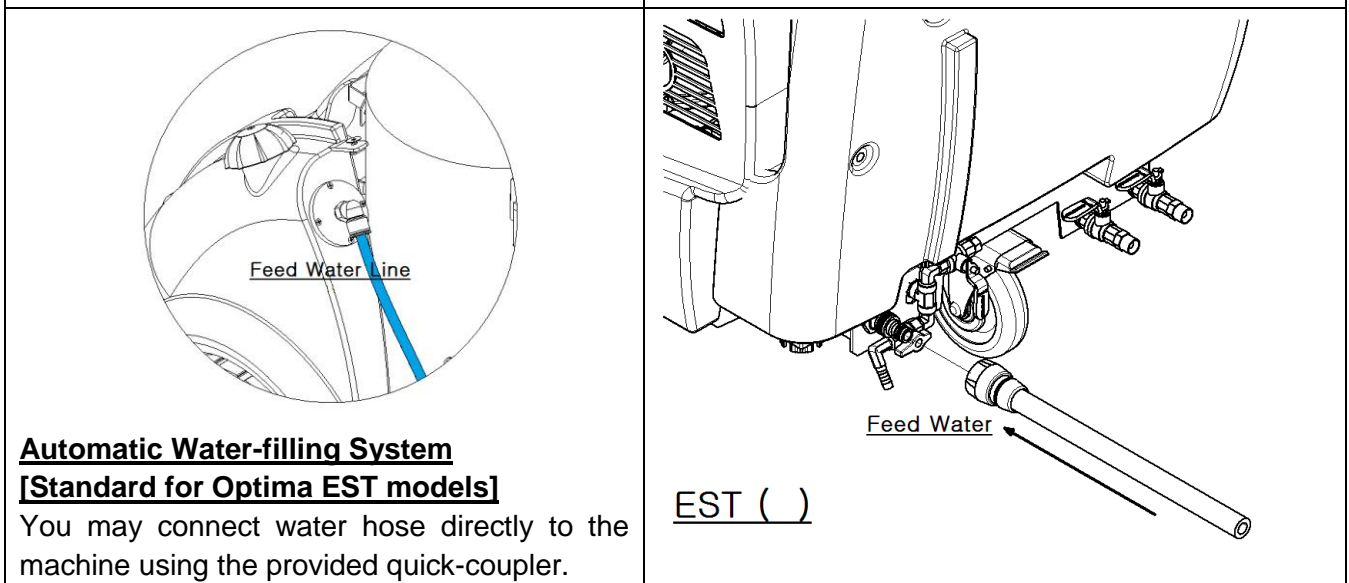
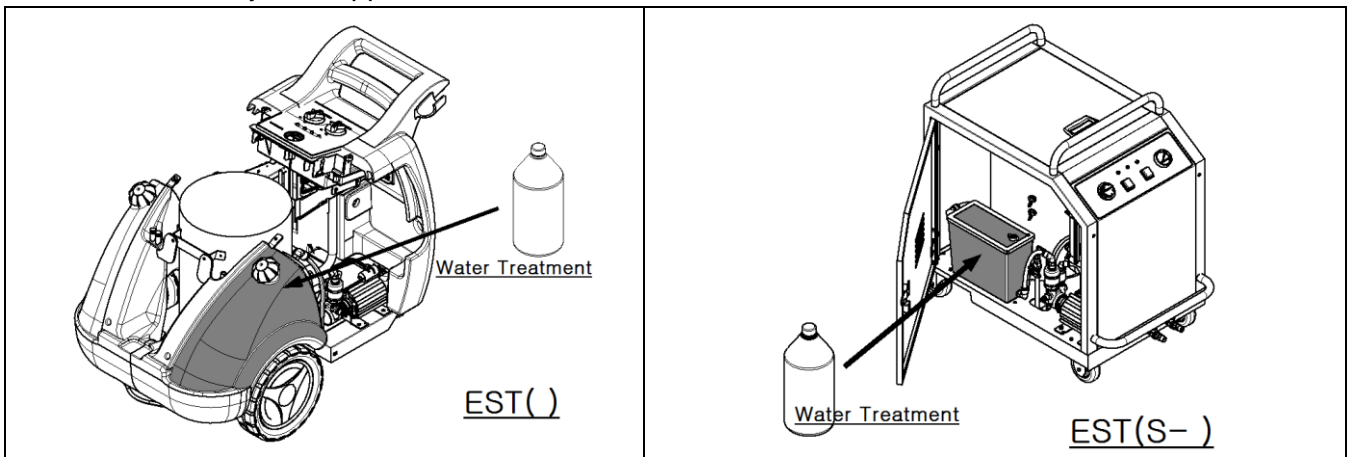

## Water Quality Matters!

Water quality can greatly affect the Optima's life span/time and performance. It is important to use **SOFT WATER**. If tap water is used, daily use of water treatment (water softening liquid) and regular sediment removal will help ensure efficient operations (see "Maintenance A & B" for more information). **Do not use distilled water. Do not put any other chemicals or detergents into the water tank or steam vessel.** The feed water temperature should be above 5°C (40°F).

### Anti-scaling water treatment

If water other than treated soft water is used, scale will build up on steam vessel walls, probe sensors and pipes. This will adversely affect the performance and life of the machine. In order to prevent this, we recommend operators to use anti-scaling agent. Simply add water treatment every day and ensure that the steam vessel is drained at the end of the day. This procedure will prevent scale build-up inside steam vessel and increase the thermal efficiency of the machine. Use manufacturer recommended steam vessel anti-scaling and de-scaling solution only.

3. Connect the machine to required power source.



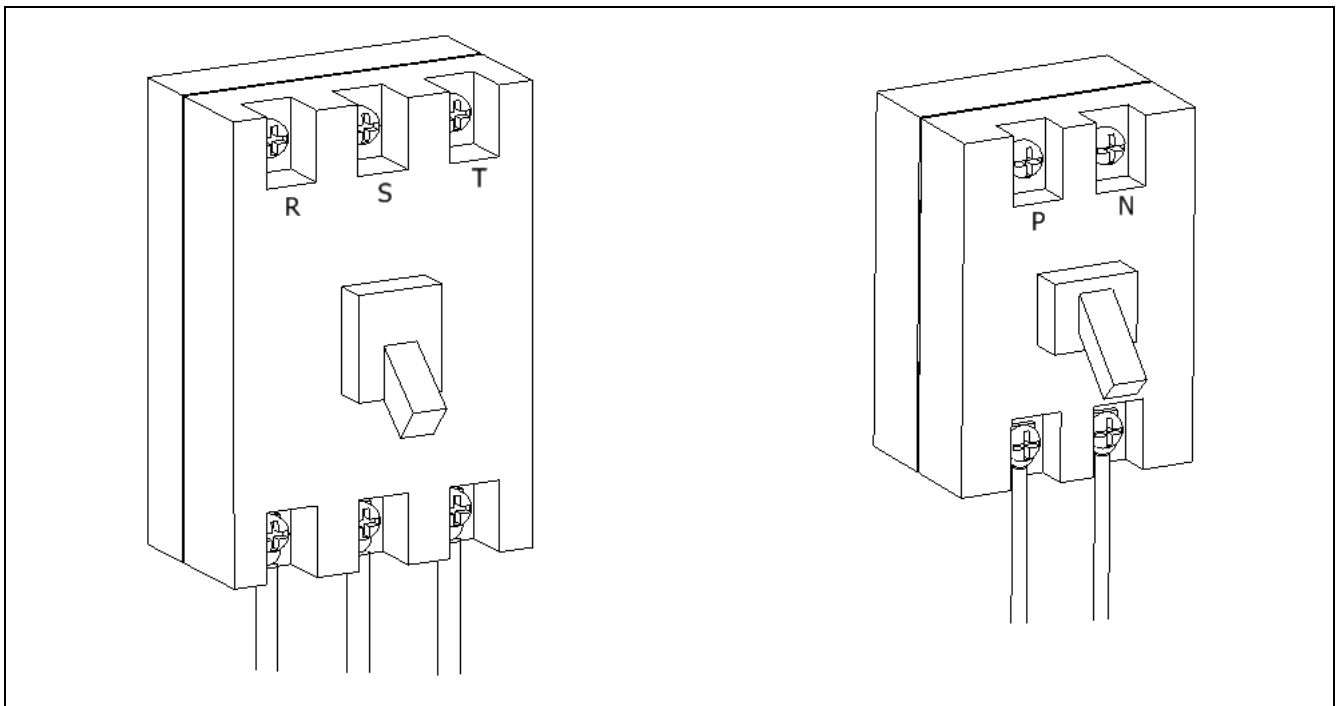



- Make sure that machine switches and breaker switches are off before connecting the machine to a breaker. Connect the power cable, R, S, and T for 3 phase models [EST (12K, 18K, 27K)] and P and N for the single phase model [EST (05K)] to the breaker. Connect the grounding cable to grounding point and turn on the breaker switch.



# Initial Operation

“Initial operation” means operating the machine after draining all water from the steam vessel. After completing the pre-start procedure, follow the steps below.

● light on      ✨ light flashing      🔊 alarm sound

Steps	Instructions/Corrective action	Signal indications
1	<p>Make sure the water tank is full. (If using the auto water filling system, connect water hose to water supply source, i.e. faucet and open the valve)</p> <p>Connect the power cord to the outlet. (Double-check the breaker capacity)</p>	
2	<p>Turn on the POWER switch (Emergency Stop) and then turn on the STEAM switch. You will see one of the following signal indications.</p> <p><b>A:</b> POWER and PUMP RUN light are on. The water pump supplies water to the steam vessel for about 1 minute.</p> <p><b>B:</b> The POWER light is on and the WATER light is flashing, and the alarm is on. This means the float switch in the water tank does not detect water. Add water to the water tank.</p>	<p><b>A</b> </p> <p><b>B</b> </p>
3	<p>If the alarm beeps continuously for more than 2 minutes, you will see either A or B signal indications.</p> <p><b>A:</b> If water pump runs over 2 minutes at initial operation, check the condition for the pump and water filter then reset the STEAM switch.</p> <p><b>B:</b> Insufficient water. Refill the water tank.</p>	<p><b>A</b> </p> <p><b>B</b> </p>
4	<p>When water supply reaches the lower water probe sensor, programmed normal operation will begin. You will see 2 lights (POWER &amp; PUMP), and then pump light will turn off when water reaches the high water probe sensor.</p>	<p></p> <p>↓</p> <p></p>

**Note!**

When using the Optima after draining the steam vessel, the above procedure must be repeated.

# Standard Operating Procedures

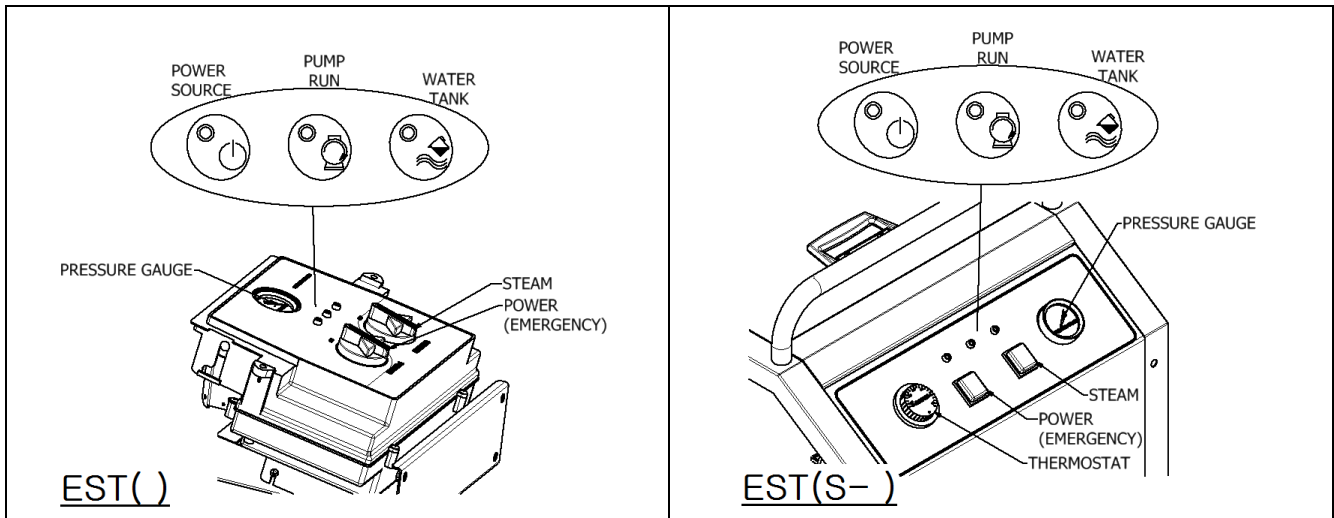

## Steps:

1. Turn on the POWER (EMERGENCY) switch, and then turn on the STEAM switch. If the alarm beeps once, and the POWER light is on, the machine is ready to operate. (If you are starting the Optima for the first time or using after draining the steam vessel, refer to “Initial Operation” on the previous page.)
2. Once heating starts, it will reach the operating pressure within 6~21 minutes (Pre-heating time varies per model).
3. After the steam pressure reaches 8 kg/cm<sup>2</sup> (116 psi), open the steam outlet valve(s) and begin to operate.



Review all safety precautions on page 1~2. Never leave the machine unattended

## **[Automatic air purge system]**

The 2014 Optima Steamer models are equipped with an electronic valve that purges air to avoid false pressure reading of the system. Whenever the thermostat reading is below 212°F(100°C), the system assumes that the high pressure in the system is due to internal air and will open the electronic valve to remove internal air. **(it automatically switches from user mode to auto operating mode)**

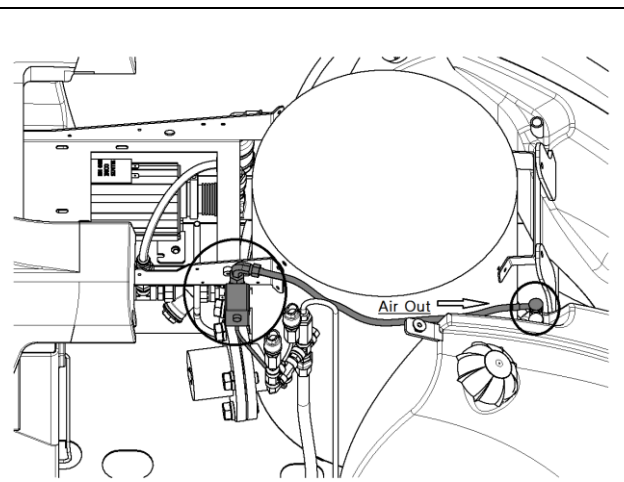

# Moisture Control

You can increase the moisture content in the steam by opening the moisture control valve. Increasing the moisture content in the steam increases water consumption and may produce water run-off.

Dry steam may persist due to extremely hot weather; adjust the moisture control valve accordingly. When cleaning and/or sterilizing interior surfaces, ensure that the moisture control valve is closed to minimize surface moisture. Wet steam may persist in extremely humid or cold weather.

## Note!

In extremely hot or dry weather conditions, using two spray guns continuously with the moisture control valve open all the way may consume steam faster than what can be replenished. In this case, the alarm will sound. Close the moisture control valve by 1/3 and allow pressure to build.

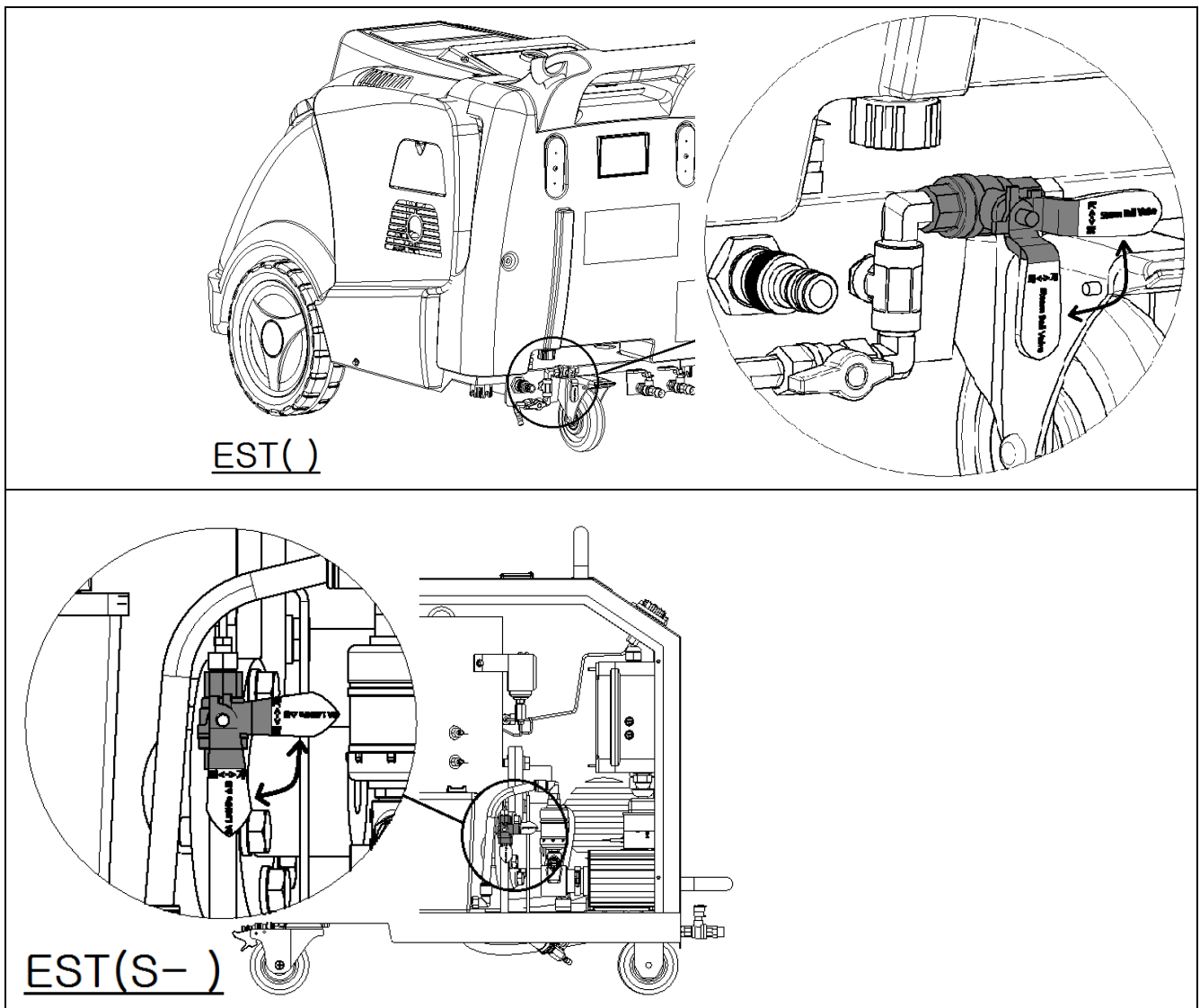

## ***Pause Operations***

---

(Follow these steps if you intend to stop using steam for more than 5 minutes temporarily.)

### **Steps:**

1. Turn the STEAM switch off.
2. Close the steam outlet valves and pull the steam gun trigger to release any remaining steam in the hose. This will prevent the release of water (cooled steam) and increase the life span of the steam hoses and guns.

### **Note!**

When manually refilling the water tank, must turn off the STEAM switch.

After refilling the water tank, turn the STEAM switch back on then resume operation.

## ***Shutdown Procedures***

---

### **Steps:**

1. Turn off the STEAM switch.
2. Turn off the POWER (EMERGENCY) switch
3. Use up existing steam in the steam vessel until the pressure drops to 1~2 bar.  
If the water from the steam vessel is milky, drain all remaining water & sediment of the steam vessel by opening the Y-strainer drain valve (cap).
4. Close the steam outlet valve and pull the spray gun trigger to release the remaining steam in the hose. This will prevent the release of water (condensed steam) at next use and increase the life span of the steam hose and spray gun.
5. In cold climates or cold weather condition, additional steps are required to prevent damages.  
(See "Freeze Prevention" on page 13).

### **Tips!**

#### Extend the life span of the Optima

1. Use soft water or clean tap water.
2. Use water treatment daily if tap water is used.
3. Always remove steam from hoses, spray guns, and the steam vessel after use.
4. Store the Optima at room temperature.
5. Remove sediments from the steam vessel regularly. (See "Maintenance")
6. Remove hardened scale from the vessel regularly. (See "Maintenance").



# Freeze Prevention



The Optima Steamer can perform in the sub-zero weather. However, it takes precautions for storage. In cold climates it is necessary to store the Optima in an area where the temperature is above freezing. Unplug the machine from electrical source and follow steps below to protect the Optima against ruptured lines and damage caused during cold climates.

## Steps:

### 1. Empty the steam vessel

Slowly open the steam drain valve or Y-strainer drain valve once the pressure is below 2bar. Keep drain valve open until next use.

**Warning! : Steam is extremely hot. Wear appropriate hand and eye protection.**

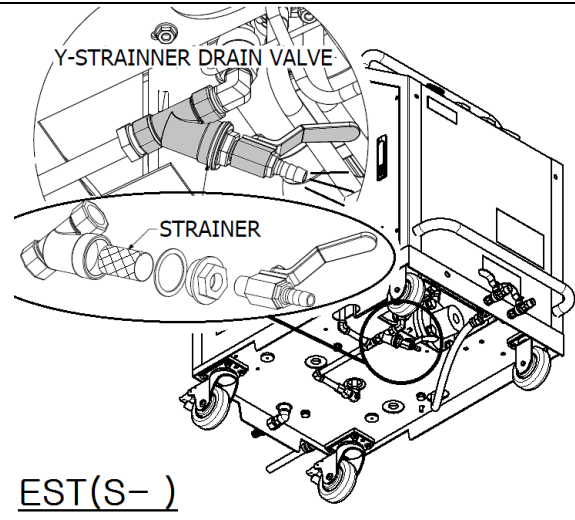
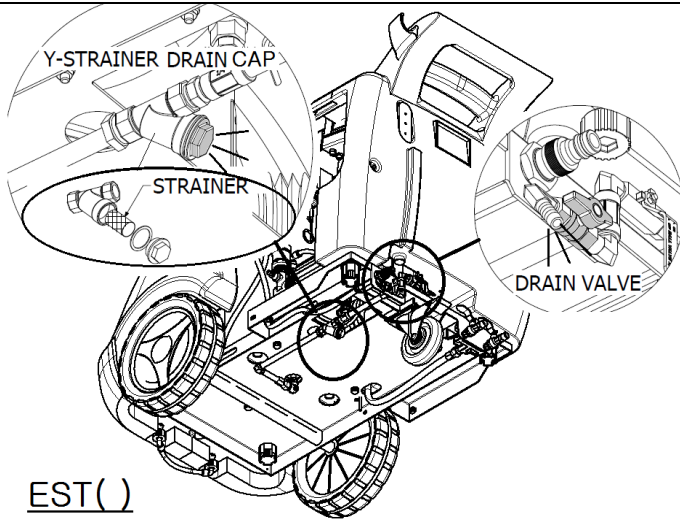

### 2. Empty the water tank.

Open the water tank drain cap at bottom side. [EST (S-) models are at side, see below drawing.]

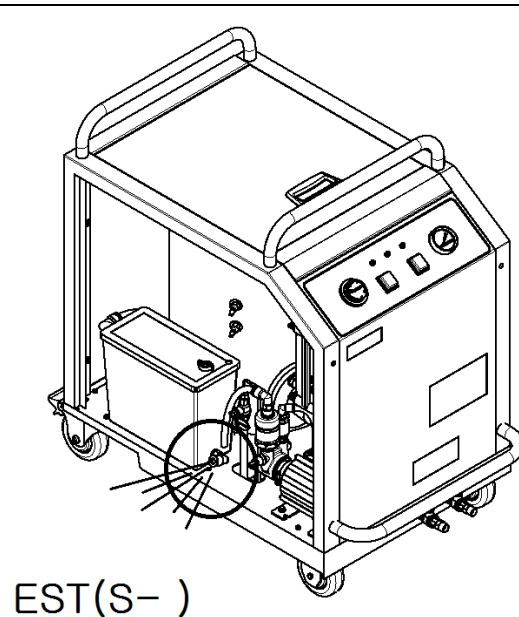
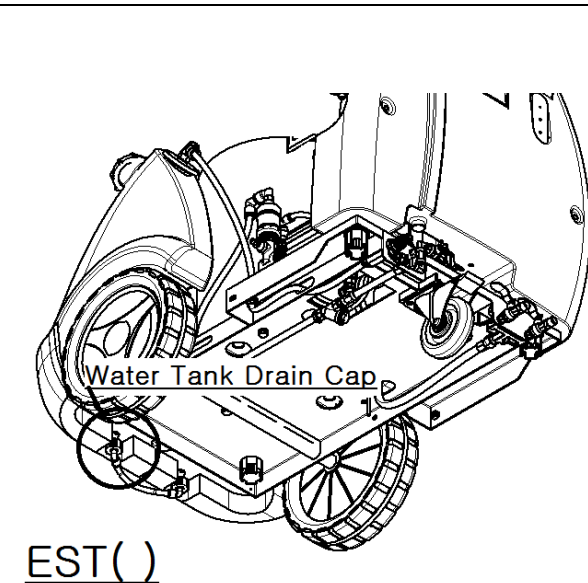

**3. Drain the water suction lines and the water pump.**

Open the steam drain valve or Y-strainer drain valve, then disassemble/detach water suction line from top of water pump and drain all remaining water using compressed air. Keep drain valve open until next use.

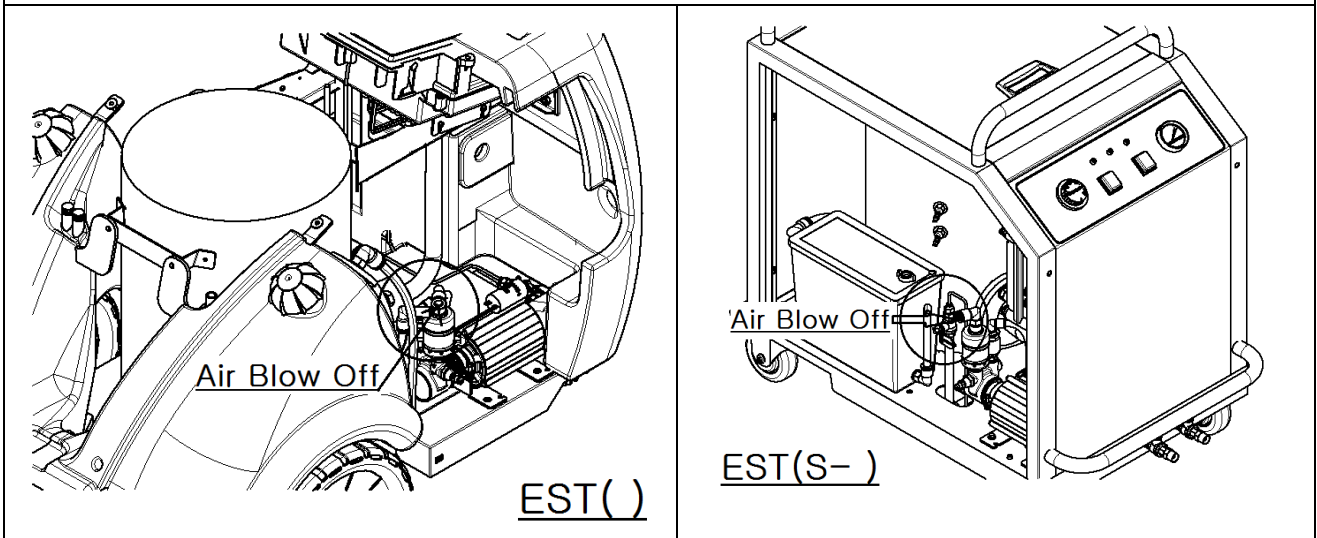

**4. Store the machine at room temperature.**

**Note!**

Doing freeze prevention maintenance can prevent costly repairs. Frozen water can rupture lines, cause malfunctions and destroy parts. Never operate the Optima if any part is frozen or suspected of being frozen. Thaw the machine at room temperature overnight. Carefully inspect the machine. If the machine is visually damaged or performs abnormally, immediately turn off the machine and contact your distributor or manufacturer.

# Maintenance

## Warning!

Unplug the machine from electrical source and allow it to cool off before conducting maintenance.

Wear appropriate safety protection.

**Note:** To avoid unexpected downtime, keep up with maintenance schedule.

## Maintenance Schedule

	Maintenance Items	Daily	Monthly or as needed	Every year or as needed
<b>A</b>	Add water treatment. (Softener)	✓		
<b>B</b>	Check for/drain sediments from steam vessel	✓		
<b>C</b>	Drain water tank		✓	
<b>D</b>	Check/replace water filter		✓	
<b>E</b>	*Check/clean water probe sensors		✓	
<b>F</b>	*Perform steam vessel de-scaling			✓

\*The frequency of these maintenance items may vary based on the hardness of water in your area.

### A. Add water treatment.

Add the recommended dosage of water treatment into the water tank. Use a TDS meter to determine the hardness of water in your area.

(See “Pre-start Procedure” Step #2 Page 7)

#### [Recommended Water Treatment (WaterCon) Dosage]

TDS Meter Reading (ppm)	0 - 40	40 – 120	120 - 425	425 - 1000
Hardness description	Very Soft	Soft	Hard	Very Hard
Dosage per every 100L (27gal) of water	No dose	25ml	50ml	100ml

Scale is caused by dissolved mineral in water settling on internal surfaces. Scale build-up can greatly impact steam vessel longevity and operating efficiency. Adding water treatment will help prevent scale from forming on the inside wall of the steam vessel and protect against sensor malfunction. Only add water and the manufacturer approved anti-scaling agent to the water tank.

**B. Check for/drain sediments from steam vessel**

Open the drain valve and check the color of the water. If the water is milky, drain all remaining water & sediment from the steam vessel by opening the Y-strainer drain valve or cap.

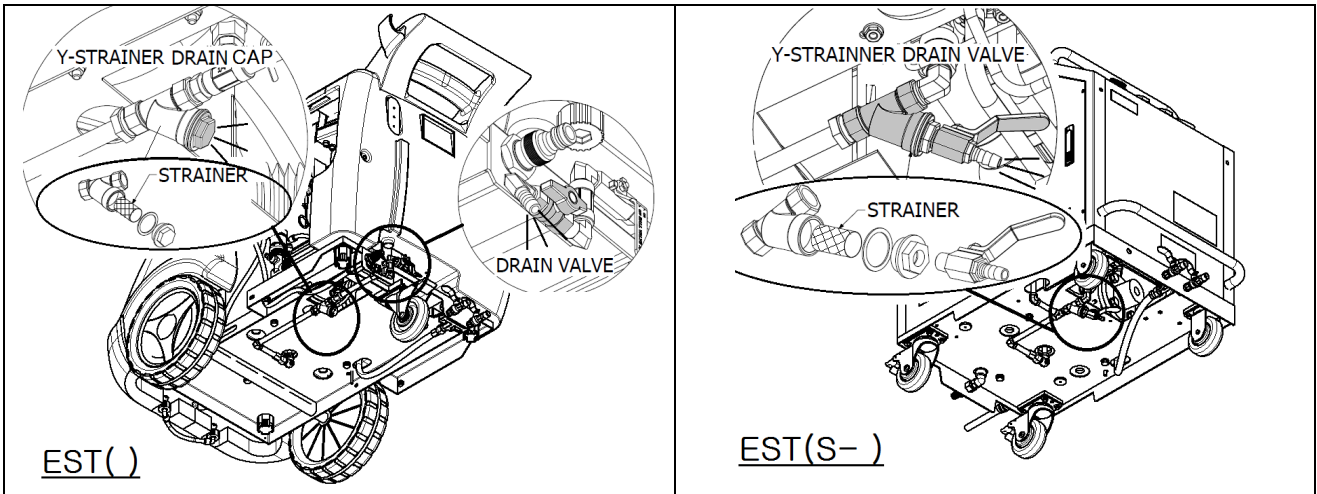

**C. Drain water tank**

Drain out all sediment of water tanks by removing the drain cap from bottom of the tank. This will flush out sediments which may have settled to the bottom of water tanks.

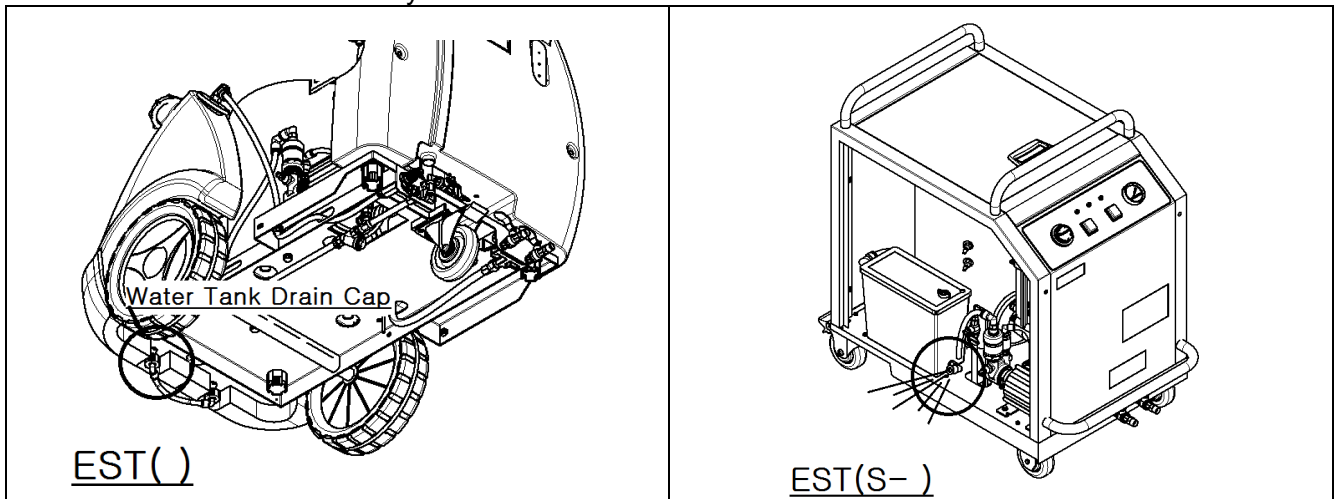

**D. Check/replace water filter.**

Check the water filter routinely and replace as needed.

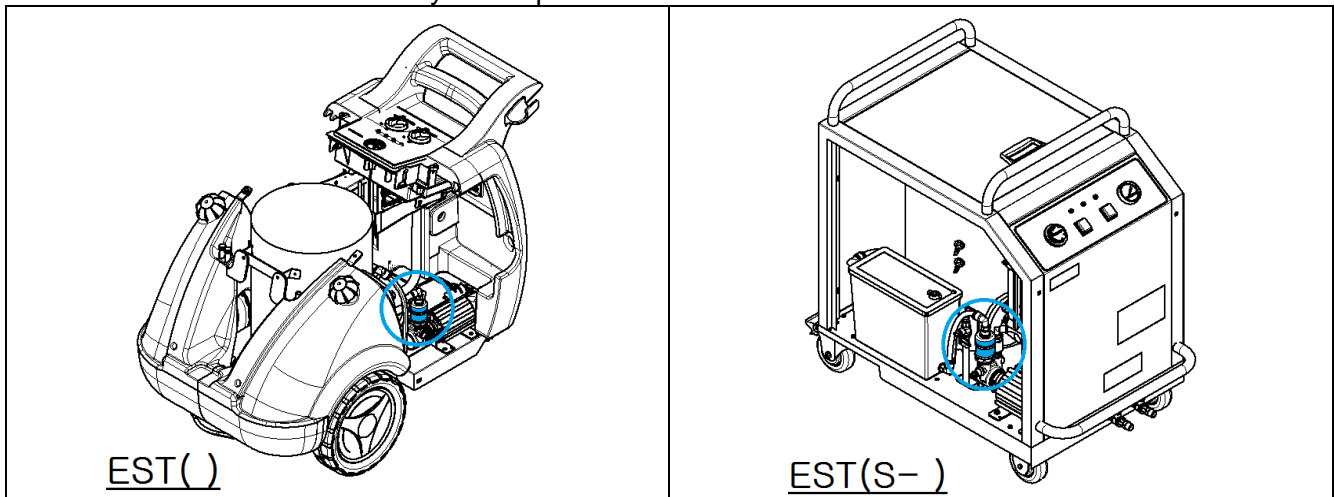

### E. Check/clean water probe sensors.

The Optima has two water probe sensors (low and high). Scale build-up on the water probe sensors can affect sensor accuracy and will prevent the machine from operating normally.

**What you will need: screw driver (+), 14mm deep socket wrench, breaker bar (DO NOT USE A POWERED/TORQUED WRENCH!!!), sandpaper, and Teflon tape.**

#### Steps:

1. Unplug the electric cord and let the steam pressure drop to "0."
2. Cool down and drain the steam vessel by opening the drain valve.
3. Remove the top cover or open the lateral door and disconnect the sensors from wiring.
4. Remove the sensors from the vessel using 14mm deep socket wrench.
5. Using sandpaper, scrub the sensors clean. Replace them if necessary.
6. Wrap the threads of the sensors with Teflon tape at least 6 times and insert the sensors using tools.

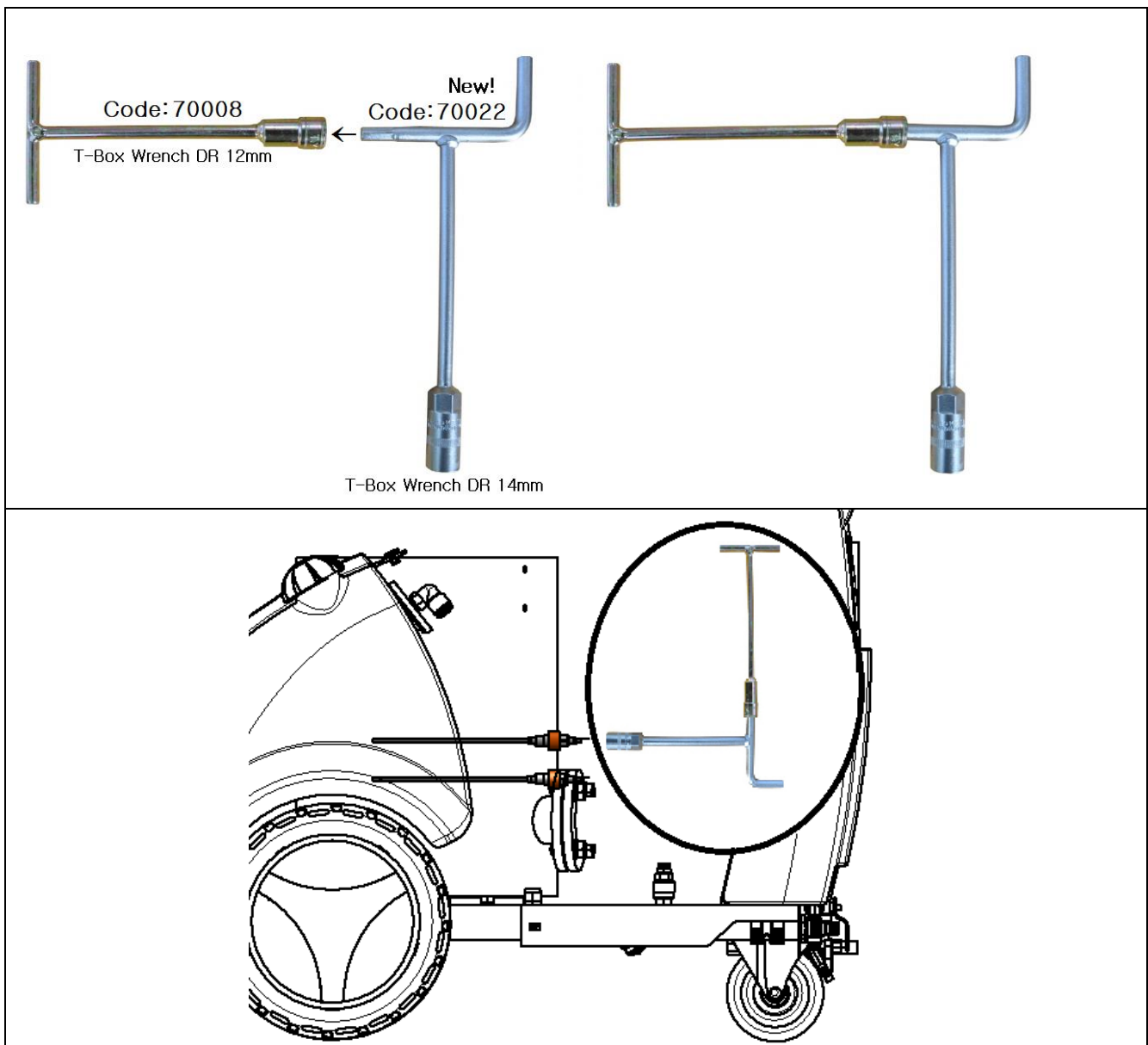

## F. Perform vessel de-scaling.

**What you will need: screw driver (+), wrenches, 10mm T-box wrench, container (14liters or larger), 14 liters (3.7gal) of diluted de-scaling liquid, and 2 liters (.5 gal) of clean tap water.**

### Steps:

1. Remove the top and lateral covers.
2. Open the drain valve and release all water from the vessel. Close the drain valve afterwards.
3. Disconnect the wiring from high & low water probe sensors.
4. Make sure the water tank is full or disconnect the wiring from the float switch.
5. Wear gloves and goggles and prepare descaling solution based on the instruction by the chemical supplier.
6. Detach the water suction line from the water filter and submerge the tip into the container.
7. Detach one of the steam hoses from the steam outlet and open the steam outlet valve.
8. Turn on POWER switch then turn on STEAM switch to activate the water pump. Fill the vessel with 14 liters (3.7 gallons) of diluted de-scaling liquid.
9. Submerge the tip of the water suction line into the container filled with 2 liters (0.5 gallons) of clean tap water to wash out the water pump. Once water starts coming out of the steam outlet, turn off the STEAM switch.
10. Let the machine sit for the time instructed on the de-scaling liquid label. Do not exceed the recommended time to avoid steam vessel damage.
11. Drain the steam vessel by opening the Y-strainer cap and temporarily remove the strainer to prevent scale from clogging the line.
12. To wash out the steam vessel and lines, supply clean water to the steam outlet valve until you cannot see scale coming out of the Y-strainer.
13. Reassemble the Y-strainer and the water suction line and connect the water probe sensors to the wiring.

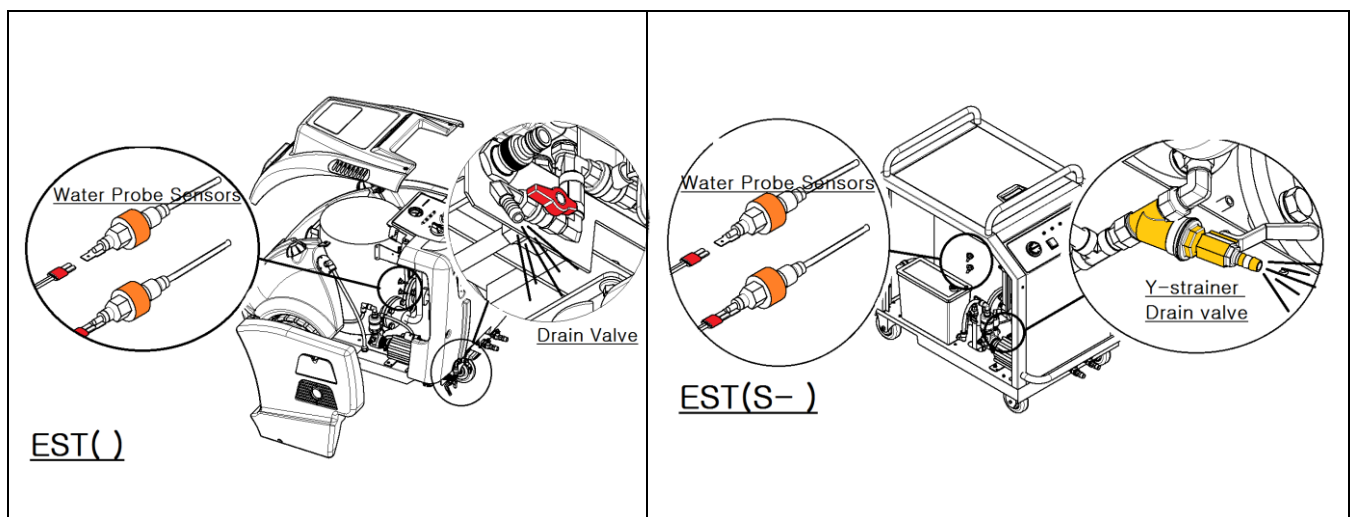

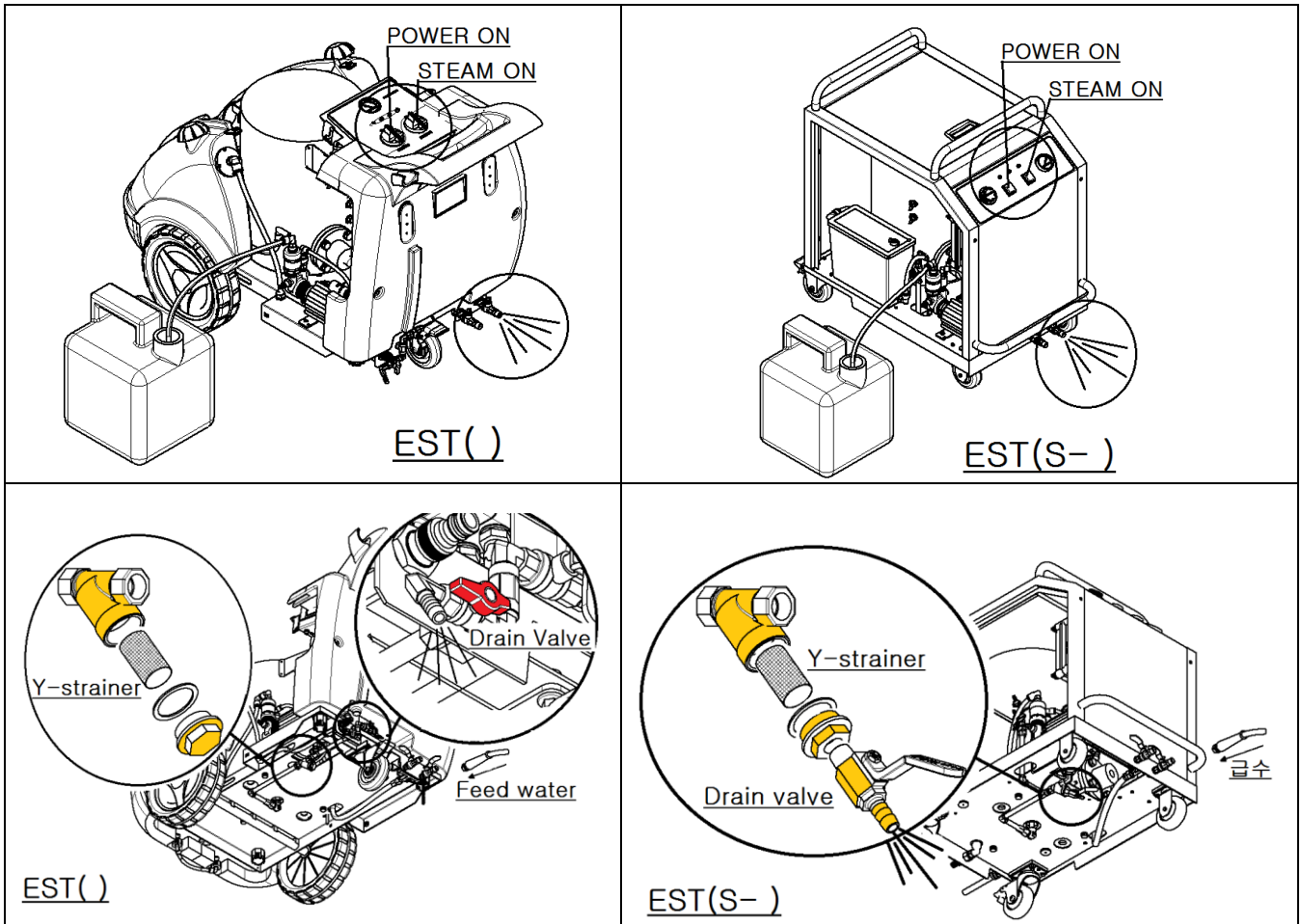

**Note!**

Check local regulations regarding the disposal of de-scaling liquid. Depending on the de-scaling product used, a special disposal method may be required.

# Safety Features



The Optima was designed with operator safety first in mind. There are multiple safety features that protect both the operator(s) and the Optima. Understanding the Optima's safety features will enhance the user experience and assist you when troubleshooting

## The Optima's Main Safety Features:

1. **Pressure control switch:** The pressure switch is permanently set on to both 8bar (116 psi) and 10 bar (145 psi). The heaters will shut off if the steam pressure exceeds the preset pressure on 8bar and will automatically reactivate when pressure decreases below 7 bar (101.5 psi). 10 bar pressure switch are for the safety device on emergency only.
2. **Thermostat:** The temperature setting is between 194~212°F (90~100°C). It controls the electronic valve for air purge. If the thermostat reading is below the preset range, the machine will release air from inside the steam vessel at initial pressurizing stage. This will prevent any machine operation interference caused by false pressure reading due to internal air.
3. **Safety valve:** Pressure is released when steam pressure exceeds 9.5bar (138 psi).
4. **The low water probe sensor:** The sensor prevents the vessel from heating without sufficient water in the steam vessel.
5. **Non-return valves:** Two non-return valves prevent steam from back drafting.
6. **Y-strainer:** The Y-strainer is connected to the steam drain. It is designed to break first before other important parts when a freeze rupture occurs.
7. **Water pump running time:** The water pump is programmed to shut off after running for 40 seconds (in normal operations) in order to avoid dry running.
8. **Programmed operating:** The intelligent system checks for the machines condition and takes necessary steps to prepare for the machine for a safe operation.

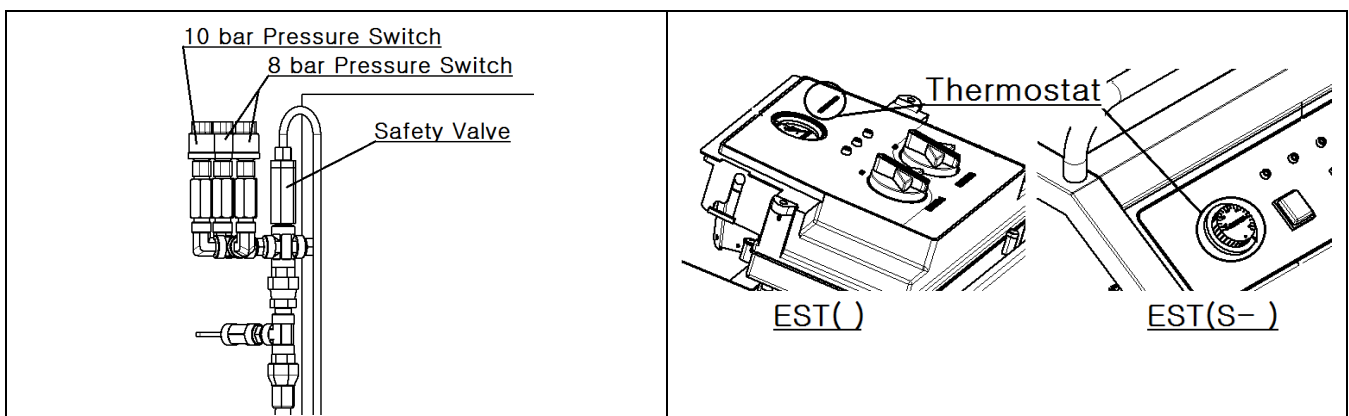



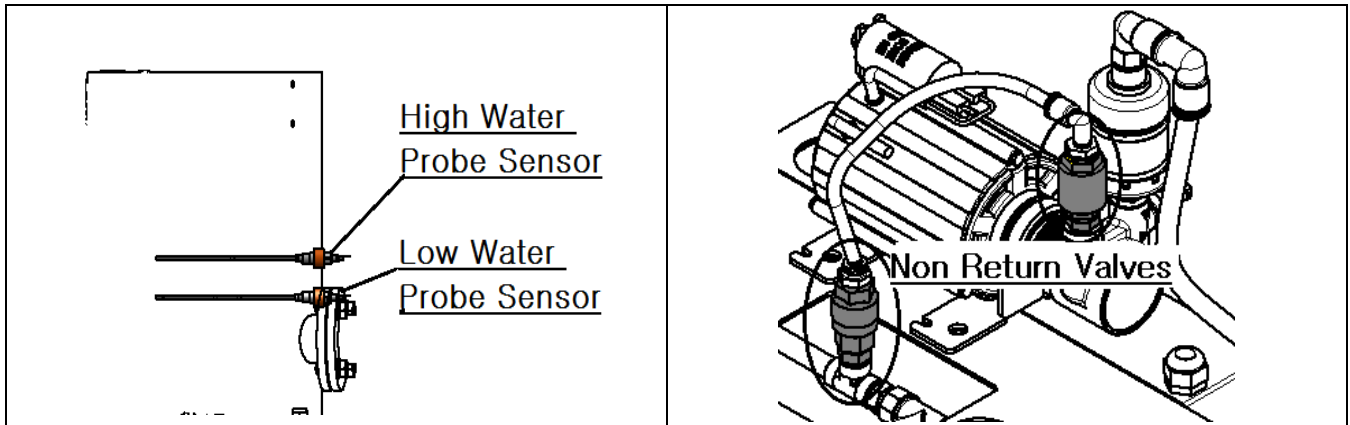

**Required Conditions for the electric heaters to Activate:**

1. The POWER and STEAM switches are on;
2. The FLOAT switch in the water tank detects liquid;
3. The low water probe sensor in the vessel detects water; AND.
4. The steam pressure should not be below 7bar.

**Required Conditions for the Water Pump to Activate:**

1. The POWER and STEAM switches are on;
2. Water is filled above the FLOAT switch level in the water tank;
3. Water is not detected by the high water probe sensor; AND
4. The water pump has not been running over 40 seconds during normal operations; OR
5. The water pump has not been running over 2 minutes at initial operation.

**Warning! When steam pressure arises above 8 bar (116psi):**

When steam pressure gauge indicates above 8bar, you must turn off both STEAM & POWER switches. Confirm the cause and take steps necessary before operating the machine again. (Refer to "Troubleshooting Guide" number 9)

# Troubleshooting Guide

When a malfunction occurs, refer to the troubleshooting guide below. If the problem persists, please contact your local distributor and report the problem by referring to the reference number on the left hand side.

## LED Lights Indication



Main POWER on.



Electric Heater



Water pump run on.



Water pump over-run flashing



Low water level detection error on.



Water tank level low flashing



Continuous pressure increase over 8bar.



Continuous pressure decrease.









Alarm beeps once.

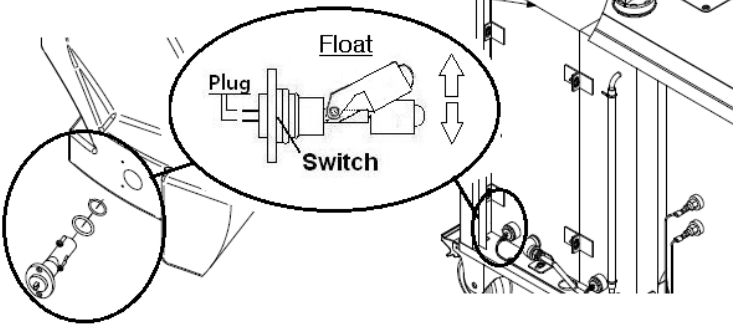

Alarm beeps continuously.

No.	Lights & Alarm Indications	Description, Cause
		Remedy
1		No lights on and no alarm sound when POWER & STEAM switches are on due to; 1) No power supply (power plug disconnected) 2) Blown fuse
		1) Check your electrical power source and power plug 2) Replace the fuse.

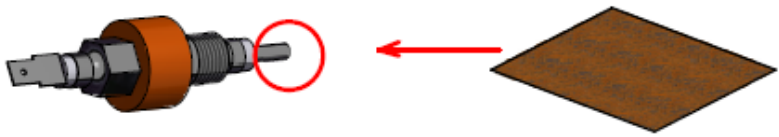
2		<p>The POWER and STEAM switches are on. The POWER light is on and the alarm beeps once.</p>
		<p>This is normal operating condition.</p>
3		<p>The POWER and STEAM switches are on. The POWER &amp; WATER PUMP light are on, and the alarm beeps once.</p>
		<p>This is normal operating condition. The PUMP light will go off momentarily. (See page 9)</p>
4		<p>Float switch is not detecting water in the water tank due to:</p> <ol style="list-style-type: none"> <li>1) Water shortage; OR</li> <li>2) Malfunction of the float switch in the tank.</li> </ol> <p>1) Add water to the water tank. 2) Disconnect the wire from the float switch. If the signal clears, replace the float switch.</p>
		
5		<p>Both high and low water probe sensors cannot detect water in the steam vessel because:</p> <ol style="list-style-type: none"> <li>1) Not enough water is present in the vessel; OR</li> <li>2) Both water probe sensors are malfunctioning due to scale build-up</li> </ol>
		<ol style="list-style-type: none"> <li>1) Wait until the pump refills the vessel. Once the alarm is deactivated, normal operation can resume.</li> <li>2) Clean the water probe sensors. (Refer to Guide No.6 figure)</li> </ol>

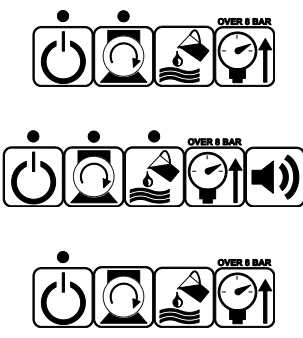
6		<p>The low water probe sensor cannot detect water in the steam vessel because:</p> <ol style="list-style-type: none"> <li>1) The low water probe sensor is defective; or</li> <li>2) The low water probe sensor's connection cable is disconnected; or</li> <li>3) The low water probe sensor cannot detect water due to scale built-up.</li> </ol> <p>1) Check the low probe sensor and replace it. 2) Check the connection cable 3) Clean the low probe sensor with sandpaper then re-install</p>  <p><u>Water probe sensor</u>                      <u>Sandpaper</u></p>
7		<p>When the both high/low water probe sensors are in short circuit:</p> <ol style="list-style-type: none"> <li>1) Both probe sensors are defective; or</li> <li>2) Sensor's line itself got in short circuit.</li> </ol> <p>1) Check the low probe sensor and replace it. 2) Check the connection cable and fix it.</p>
8		<p>The water pump has run overtime:</p> <ol style="list-style-type: none"> <li>1) At initial operation, the water pump has a 2 minute running time limit. Once low water probe sensor detects water, the water pump is programmed to run up to 40 seconds.</li> </ol> <p>1) Check for blockage in the water line. Clean or replace water filter, pipes and/or water pump. Reset the STEAM switch.</p>
9		<p>The steam pressure arise above 8bar due to:</p> <ol style="list-style-type: none"> <li>1) At initial operation, the water pump ran continuously.</li> <li>2) The water probe sensor is not detecting water and the water pump is running continuously.</li> <li>3) Pressure is over 8bar and the heaters are still on.</li> </ol> <p>1) ~ 2) Scale build-up is preventing water probe sensors from detecting water in the steam vessel → Clean or replace water probe sensor. 3) Turn off all switches and contact your distributor immediately.</p>

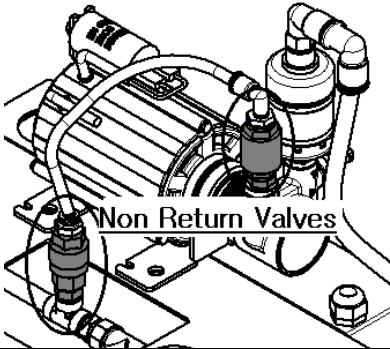
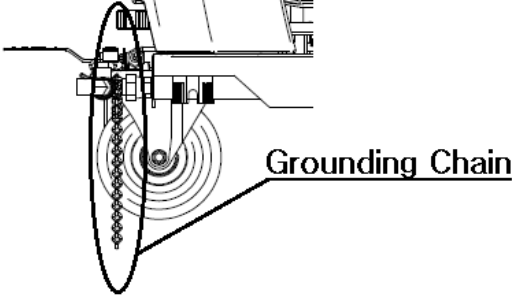
10	The steam pressure drops; and the water tank become hot.	Water or steam in the vessel traveled backwards into the water tank due to damaged non-return valves.
		<p>Clean or replace the non-return valves.</p>  <p>The diagram shows a mechanical assembly with two cylindrical components labeled 'Non Return Valves'. These valves are connected to various pipes and hoses. One valve is positioned vertically, and the other is positioned horizontally. The label 'Non Return Valves' is centered below the two components.</p>
11	Water or steam is leaking from underneath the machine.	<p>1) Y-strainer has cracked due to freezing weather condition. 2) Safety valve broke open due to overpressure in the vessel.</p> <p>1) Thaw the machine at room temperature. Inspect it for additional damages. Replace the Y-strainer and other damaged part(s) if any. (See "Freeze Prevention" on page 13~14) 2) If the safety valve opened at below 8bar, replace the valve. If the safety valve opened at over 8bar, then contact your distributor.</p>
12	Static electricity on the spray gun or the machine.	<p>The machine is not grounded properly</p> <p>Ensure that the machine is grounded using the grounding chain located at the rear bottom of the machine.</p>  <p>The diagram shows a side view of a machine's rear bottom section. A vertical chain of metal links, labeled 'Grounding Chain', is attached to the machine's frame. The chain extends downwards and then horizontally to the right, where it connects to a ground symbol. The label 'Grounding Chain' is positioned to the right of the chain with a line pointing to it.</p>

# Technical Service Request Form

Thank you for using our products.

When you encounter any problems using the Optima Steamer, please fill out the form and email it to [tech@sjecorp.com](mailto:tech@sjecorp.com).

We will be in contact with you until the issue is resolved to your satisfaction.

No	Items that should be checked basically	Remark
1	What is the serial number of the machine?	
2	Is water tank full?	
3	How many hours per day average do you operate your machine ?	
<b>Continue to items below after the POWER and STEAM switches are on</b>		
4	Does the alarm beep continuously?	
5	Please check 3 LED lights on the control panel box and let us know indication of them as light-on, flashing or off condition in each blank below.	
	Power source	Feed pump
	Water tank	
6	Is there a sudden increase of the pressure gauge up to 10bar?	
7	Is cold water jet shooting out from steam outlet valves?	
Company		Name
E-mail		Phone

**SJE Corporation Ltd.**  
**OPTIMA STEAMER SERIES LIMITED WARRANTY**

SJE Corporation Ltd. hereby warrants that new Optima Steamers purchased directly from SJE Corporation Ltd., headquartered in Busan, South Korea will be free from defects in material and workmanship for the period of time stated below, subject to certain limitations.

**OUR WARRANTY POLICY**

This warranty is not transferable and covers replacement parts only. This warranty does not cover any consequential damages or business loss.

**THE PERIOD OF WARRANTY**

The warranty on your Optima Steamer is six (6) months from the date of purchase by the original owner against defects in material and workmanship.

**GENERAL EXCLUSIONS**

General exclusions from this warranty shall include any failures caused by:

- a. Installation of parts or accessories that are not genuine Optima Steamer parts.
- b. Abnormal strain, neglect, or abuse.
- c. Lack of proper maintenance.
- d. Accident or collision damage.
- e. Alteration, modification, disassembly, unauthorized repair, or changing factory settings without consulting with SJE Corporation Ltd.
- f. Damage or malfunctions resulting from natural calamity, theft, accident, vandalism, abuse due to misapplication and/or improper site conditions.

**SPECIFIC EXCLUSIONS**

Items not covered under warranty include:

- a. Parts replaced due to normal wear or routine maintenance.
- b. Consumable or wearing items requiring replacement as part of normal operation including, but not limited to, steam hoses and guns.
- c. Any transportation or travel costs.
- d. Reimbursement for rental units while repairing warranty items.
- e. Normal maintenance items such as: draining tanks and steam vessel, descaling, filter and sensor changes, vessel cleaning, tightening and sealing bolts and fittings and others stated in the user manual.
- f. Failure caused by water scale problem due to local water conditions.
- g. Claims made under fraudulent situations.
- h. Damage, problems or failure caused by factors external to the Product including, but not limited to, faulty or poor external electrical wiring, incorrect or faulty power supply, voltage fluctuations, over voltage transients or electromagnetic interference, inadequate or faulty water or fuel.

**CUSTOMER'S RESPONSIBILITY**

Under this warranty, the customer's responsibility shall be to:

- a. Operate and maintain the machine as specified in the instructions manual.
- b. It is the original purchaser's responsibility to contact SJE Corporation prior to any repairs during the warranty period. Failure to do so will void warranty.
- c. Give notice to SJE Corporation Ltd. of apparent defects within seven (7) days after discovery.
- d. Provide proof of purchase, purchase date, and serial number of the warranty item(s).

**For warranty service request, please e-mail [tech@sjecorp.com](mailto:tech@sjecorp.com) or call +82 51 521 3200.**

**SJE Corporation Ltd. recommends that you read the Operating Instructions, and in particular the troubleshooting section of the Operating Instructions before you make a Warranty service call.**



**[Head Office]**

78-21, Sandan 7-Ro, Jeongwan-Myeon, Gijang-Gun, Busan, South Korea

Tel : +82 51 521 3200 / Fax : +82 51 521 3305

E - mail : [info@sjecorp.com](mailto:info@sjecorp.com), <http://www.sjecorp.com>

**[US Office - Steamerics, Inc]**

808 HINDRY AVENUE # E INGLEWOOD, CA 90301, United States / Tel : +1-310-327-8900 (US Office)